

产品图纸 CS080006 (Drawing of sheet metal deep drawing part CS080006)

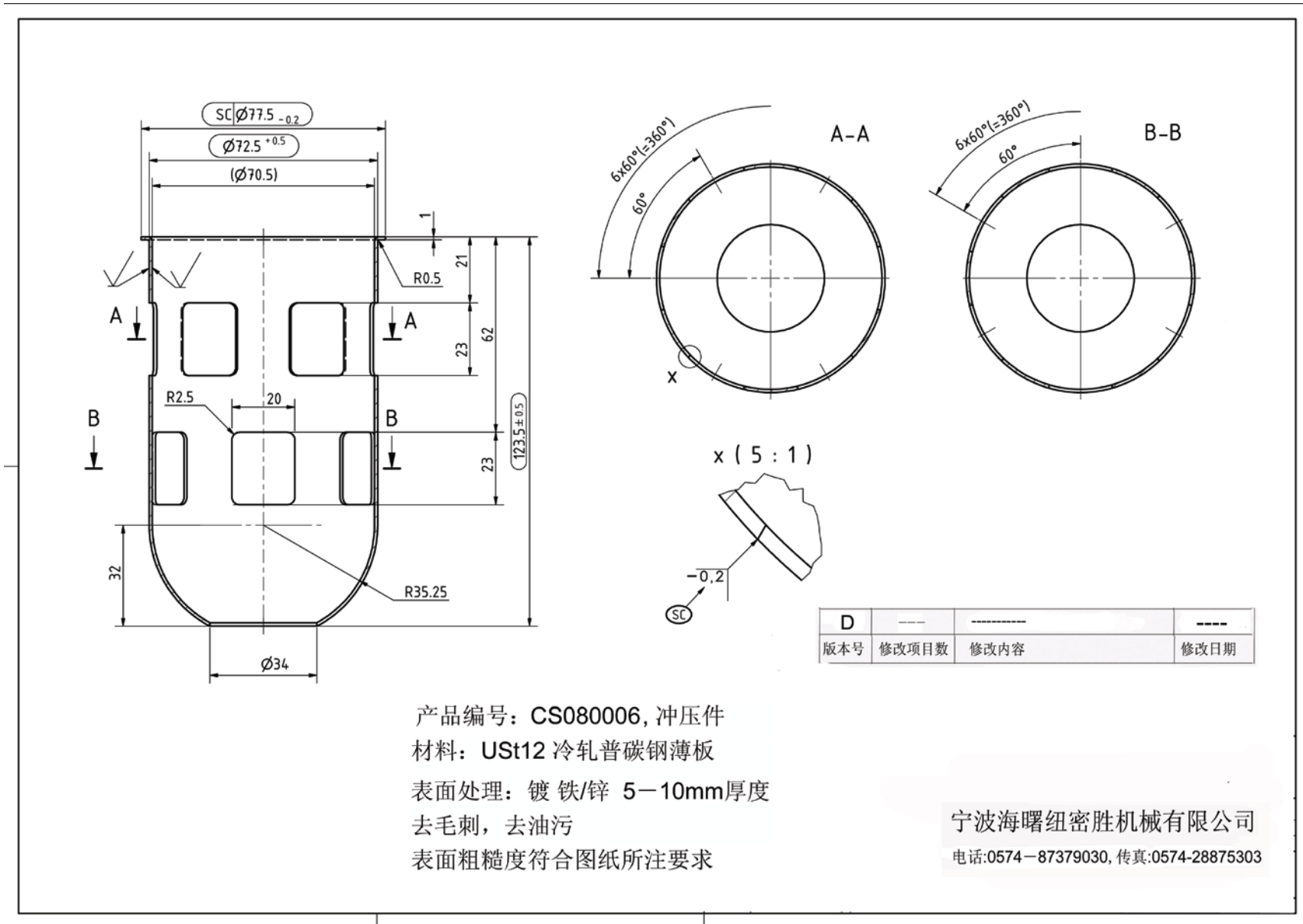

产品图片(Photos of this product)



拉伸模具图片(Photos of the deep drawing mould of this product)



检验报告单(Inspection Report)

检验单号(Inspection Report #): <u>QC-IR-1307106-CS080006-#20140109002</u> ;					客户相关信息 (外贸部填写) (Customer Info)										
纽密胜订单编号(PI #): <u>#1307106</u> ;			纽密胜产品编号 (Acculine P/N): <u>CS080006_D版本</u> ;		客户订单(Customer PO)# _____;										
检验人员 (Inspector): <u>John</u> ;			检验日期(Inspection Date): <u>2014-1-9</u> ;		客户产品编号(Customer PN): _____;										
AQL 品质水平: <u>1.5</u> ;		批次数量/件 (Lot size, pcs): <u>10000个(pcs)</u> ;			抽验数量(Inspected number): <u>38个(pcs)</u> ;										
检验工具 (Inspection tools): A卡尺(Caliper), B千分尺(Micrometer), C高度尺(Height comparator), D百分表(Dial indicator), E螺纹规(thread gauge), F塞棒(plug gauge), G环规(ring gauge) H投影仪(Projector), I三坐标(coordination measuring machine); J半径规(radius gauge)															
除非获得买家认可,对每一个检测项目所使用的检测工具必须符合该文件要求(unless approved by Acculine, each characteristic must be checked with the tools specified by Acculine preliminarily).															
序号 (Serial)	图纸尺寸 (mm) (Characteristics)	公差范围(mm)(Inspection Limits)		检验方法 (Measurement Method)	检验值 (Actual values)										备注(Note)
		下限 (LOWER)	上限 (UPPER)		产品(Product)1	产品(Product)2	产品(Product)3	产品(Product)4	产品(Product)5	产品(Product)6	产品(Product)7	产品(Product)8	产品(Product)9	产品(Product)10	
1	材料: USt12冷轧普碳钢薄板 (material: USt12, cold rolled steel sheet)														材质报告(material certificate)
2	φ77.5	77.30	77.50	A	77.43	77.42	77.48	77.45	77.44	77.45	77.48	77.45	77.44	77.48	sc7 -0.2
3	φ72.5	72.50	73.00	G	72.54	72.56	72.56	72.58	72.55	72.57	72.60	72.60	72.62	72.60	
4	70.5	70.50	71.00	A	70.56	70.55	70.58	70.58	70.57	70.56	70.56	70.58	70.55	70.57	
5	20	19.80	20.20	A	19.95	19.98	20.00	19.97	20.02	20.00	20.03	20.02	20.01	20.03	
6	R2.5	2.30	2.70	J	ok	ok	ok	ok	ok	ok	ok	ok	ok	ok	
7	32	31.80	32.20	H	32.02	32.05	32.03	32.00	32.01	32.05	32.06	32.04	32.05	32.07	
8	R35.25	35.05	35.45	H	35.26	35.25	35.28	35.27	35.27	35.30	35.25	35.29	35.30	35.28	
9	1	0.95	1.05	A	1.03	1.05	1.05	1.04	1.05	1.05	1.04	1.05	1.04	1.04	
10	R0.5	0.30	0.70	J	ok	ok	ok	ok	ok	ok	ok	ok	ok	ok	
11	21	20.80	21.20	A	20.95	20.98	21.00	20.97	20.96	20.95	20.98	21.00	21.01	20.98	
12	23	22.80	23.20	A	23.01	23.00	23.03	23.02	23.00	23.05	23.06	23.05	23.03	23.02	
13	62	61.80	62.20	A	62.00	61.98	62.02	62.08	61.99	61.98	62.07	62.06	61.97	62.04	
14	23	22.80	23.20	A	23.02	23.04	23.00	23.05	23.04	23.04	23.00	23.06	23.05	23.05	
15	123.5	123.00	124.00	C	123.68	123.71	123.67	123.73	123.69	123.67	123.70	123.68	123.72	123.74	
16	φ34	33.80	34.20	A	34.05	34.10	34.08	34.08	34.06	34.09	34.11	34.10	34.08	34.10	
17	A-A:6x60°			目测(Visual)	ok	ok	ok	ok	ok	ok	ok	ok	ok	ok	
18	B-B:6x60°			目测(Visual)	ok	ok	ok	ok	ok	ok	ok	ok	ok	ok	
19	外观:黑色,无毛刺,无油污,无变形(optic: black galvanized, no burs, no oil or grease, no deform)			目测(Visual)	ok	ok	ok	ok	ok	ok	ok	ok	ok	ok	
20	包装单位: 每箱120pcs或120pcs的约数(packing unit: 120pcs or divisor of 120pcs)			目测(Visual)	60pcs	60pcs	60pcs	60pcs	60pcs	60pcs	60pcs	60pcs	60pcs	60pcs	
21	检验结果(Inspection Result) (Q:合格, Qualified; DQ:不合格, Disqualified)				Q	Q	Q	Q	Q	Q	Q	Q	Q	Q	
22	检验判定(Decision): 合格(Approved) _____;不合格 (Rejected) _____;	判定人员 (Decision Maker): <u>John</u> ; 日期 (Decision Date): <u>20140109</u> (yy/mm/dd);													
23	不合格应对(Reaction): 特殊放行(accepted for special reasons) _____;返工 (Rework) _____;	批准人员(Approver): _____; 日期 (Approval Date): _____ (yy/mm/dd);													

Acculine Precision Manufacturing Company is a Chinese professional supplier of custom parts including [aluminum die casting](#), [zinc die casting](#), [precision machining](#), [sheet metal stamping](#), sheet metal punching, [sheet metal deep drawing](#), [plastic injection](#), etc

[China Acculine Brief Company Introduction](#)

Acculine Precision Manufacturing Company

Room306, Bldg#22, Yaduxincun District

888# Yinxiandadao Ave West

Ningbo Zhejiang Province

315153, P.R.China

Tel:0086-574-28887315 Fax:0086-574-28875303

Email:info@acculine-mfg.com Web:www.acculine-mfg.com



FACEBOOK: <http://www.facebook.com/AcculinePrecisionMfg>



YOUTUBE: <http://www.youtube.com/user/AcculinePrecisionMfg>



LINKEDIN: <http://www.linkedin.com/company/acculine-precision-manufacturing>



TWITTER: <https://twitter.com/AcculineMfg>



GOOGLE+: <https://plus.google.com/u/0/b/115338002197538176871/>



FLICKR: http://www.flickr.com/photos/acculine_precision_mfg/