

DN Series Stainless Steel Cylinder to ISO 6432



Features:

Interchangeable to FESTO DSNU

Bores: 16~40mm

Stainless steel end caps

Stainless steel rod

Rod bearing

Materials

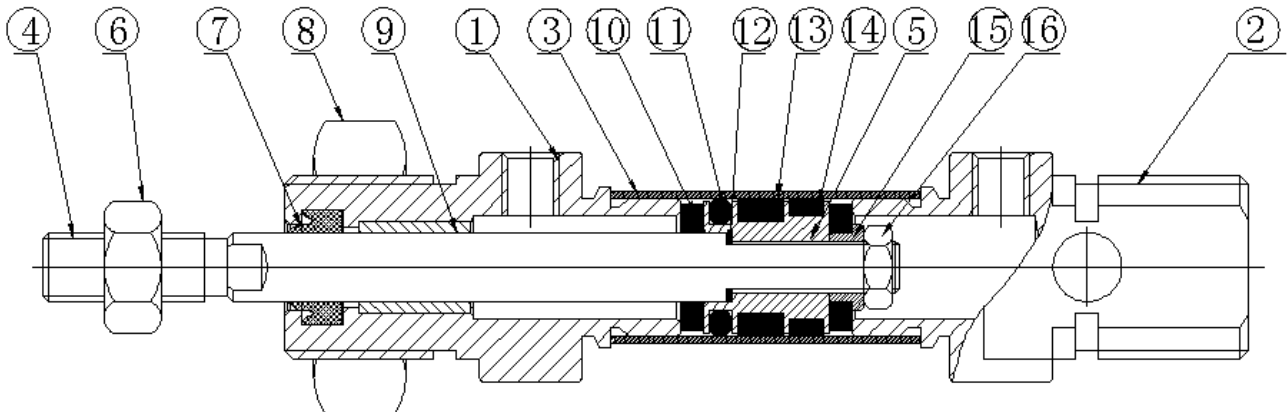

Item	Component	Material
1	Front End Cap	Stainless Steel
2	Rear End Cap	Stainless Steel
3	Tube	Stainless Steel
4	Piston Rod	Stainless Steel
5	Piston	Aluminum Alloy
6	Nut	Stainless Steel
7	Rod Sealwiper	NBR
8	Nut	Stainless Steel
9	Rod Bearing	Sintered Bronze
10	Cushion Pad	NBR
11	Piston Seal	NBR
12	O Ring	NBR
13	Magnet	Plastoferrite
14	Wear Band	PTFE
15	Gasket	Aluminum Alloy
16	Nut	Stainless Steel

Specifications

∅ [mm]	12	16	20	25	32	40
Action Type	Double- or Single-Acting					
Operating Pressure Range	1-9.0 bar					
Operating Temperature Range	0-70 °C					
Cushioning Type	Cushion Pads on both ends					
Joints	M5x0.8			G1/8		

How to Order

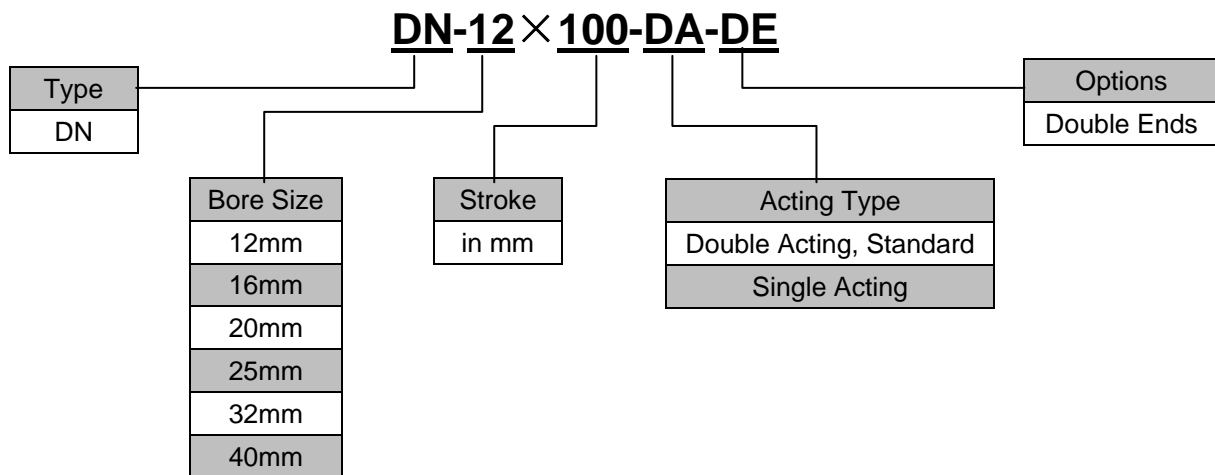

Dimensions(mm)

DN-12xStroke

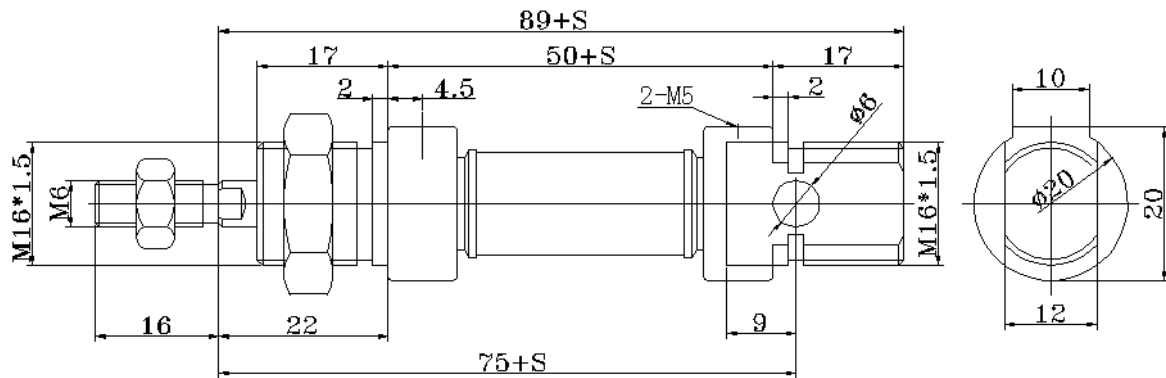

DN-16xStroke

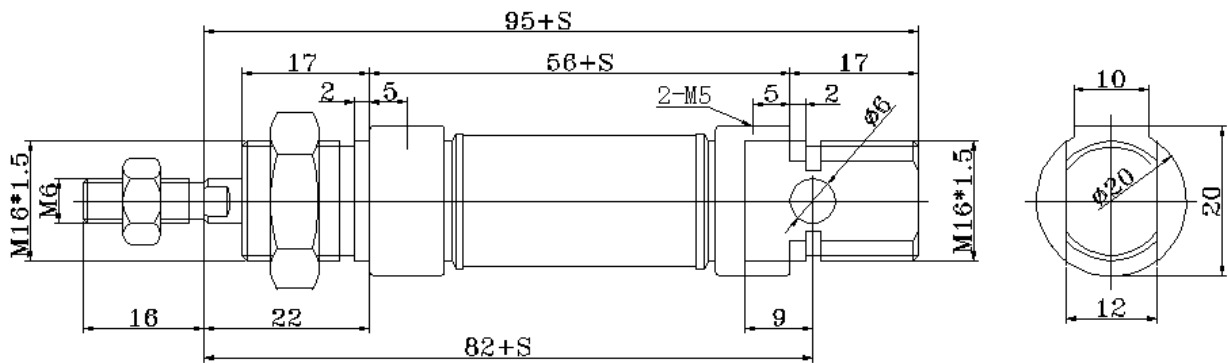

DN-20xStroke

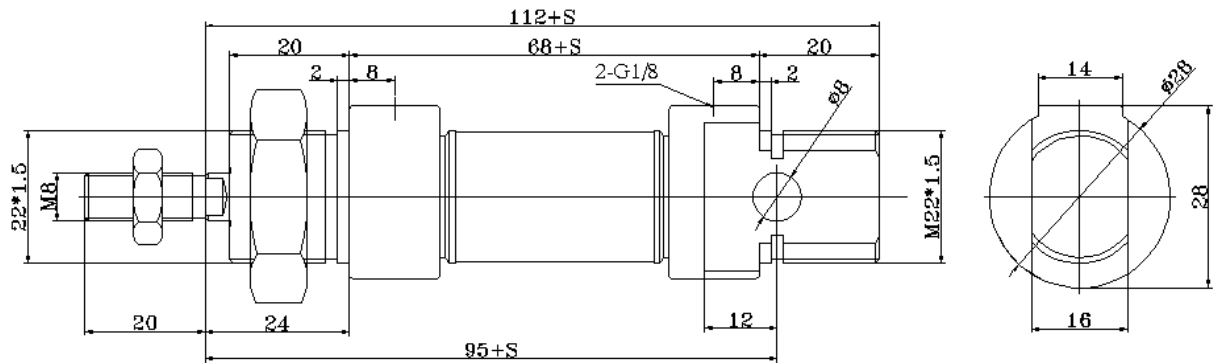

DN-25xStroke

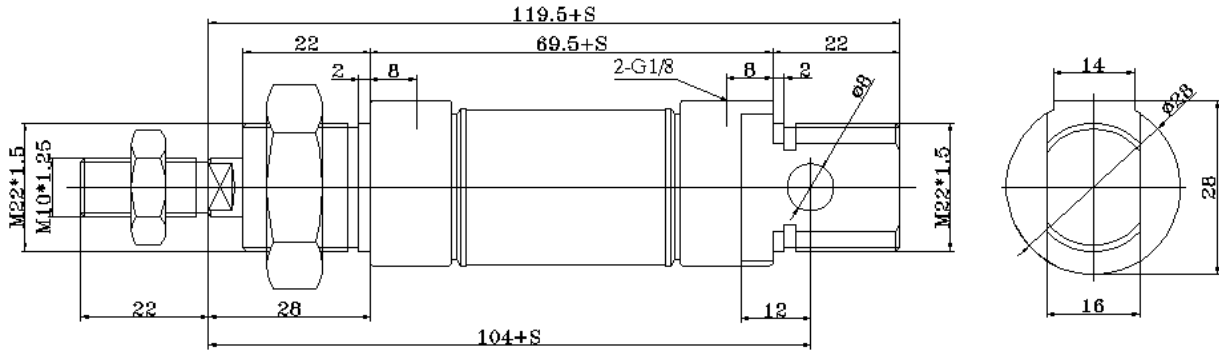

DN-32xStroke

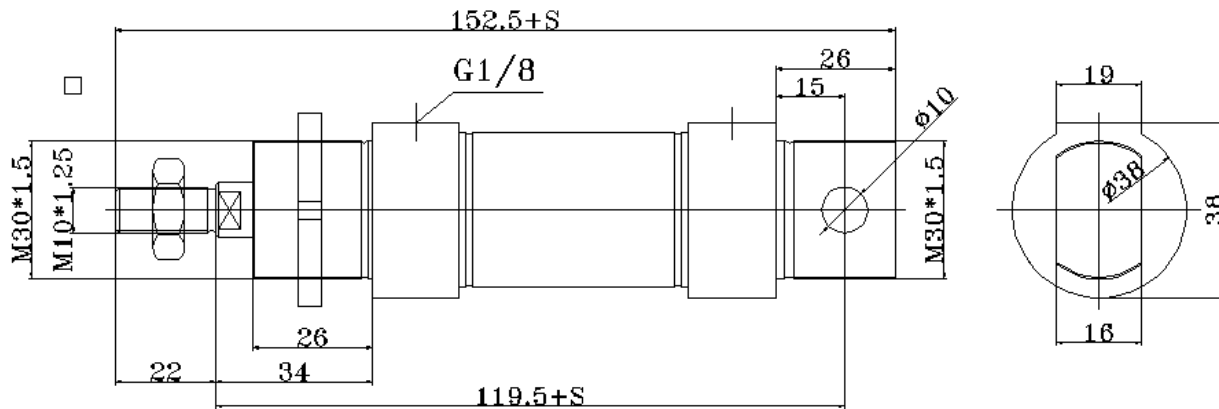

DN-40xStroke

